

Protocol Test

Racal Instruments Wireless Solutions 6402 AIME CDMA2000™ Protocol Analysis Test System

AEROFLEX
A passion for performance.



- Protocol Test System for CDMA2000 1x and EV-DV Mobile stations
- Applications in R&D, software development, mobile integration, regression testing, conformance testing
- Detailed decoding and logging of Forward and Reverse link Layer 2 and 3 messaging
- Handoff testing including soft, softer, hard handoffs and cell switching
- Power control testing including fast forward power control
- Complete coverage of data rates for 1X and 1xEV-DV to 3.1 Mbps
- Multi-cell emulation
- Script driven network emulation
- Easy to use Windows™ User Interface
- Fully controllable and repeatable testing environment with automation
- Backward compatibility for all 6204 1X-AIME scripts
- Customer specified Test cases available
- Options for Analog and Digital IQ interfaces
- Option for internal AWGN simulators

The introduction of the latest CDMA2000 standards has brought the need for test equipment to test the mobile stations during all stages of the development and deployment phases of the products. Testing is required not only in the actual product development stage but also within the integration regression testing, pre-conformance and other areas to ensure a successful deployment of the mobile stations. With long experience of testing and the cellular telecommunications industry Aeroflex has designed the 6402 AIME (Air Interface Monitor Emulator) system to undertake this testing efficiently and easily.

PRODUCT OVERVIEW

The 6402 AIME is a protocol test system for cdmaOne, and CDMA2000 (1X and 1xEV-DV), supporting current implementations of CDMA2000 terminals including those specified by 3GPP2. It is designed for use in research and development environments or for use in laboratory conformance and inter-operability testing.

The system acts as a network emulator, and it provides built in logging of signaling procedures to enable full testing and investigation. In this way the system provides a cost-effective environment to perform testing.

The system runs on the 6402 hardware platform developed by Aeroflex. It employs a Compact PCI (cPCI) architecture to provide a modular customizable design, allowing it to be configured and scaled for the user's requirements. The system is controlled by a PC either locally using an Ethernet connection, or remotely via a LAN.

The system uses a comprehensive test case editor, and it also allows for automation of test case operation. This enables testing to be run unattended to reduce costs. This is ideal for applications such as regression testing where operator intervention is not needed.

The system is able to reduce development costs by providing a comprehensive test tool with diagnostics during development. It can further reduce costs by enabling pre-interoperability testing to be run on a fully independent platform.

KEY FEATURES

SYSTEM OVERVIEW

The 6402 AIME system contains either one or two Base Station Emulators (BSE) dependent upon the configuration chosen. Each BSE is able to emulate up to three sectors on a specified frequency

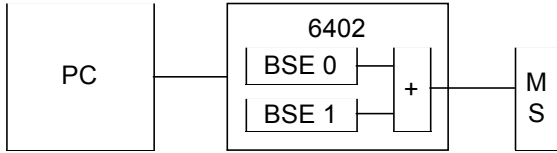

High level system connectivity

FORWARD AND REVERSE LINK CHANNEL SUPPORT

A single BSE can be configured to transmit 16 Forward Code Channels, which can be any combination of the following:

- Pilots, Sync, Paging & Quick paging Channels
- Fundamental Channels
- Supplemental Channels or Supplemental Code Channels
- Broadcast Control, Common Control & Common Power Control Channels
- Packet Data Control Channels

Additionally a separate PDCH channel can be configured to use up to 28 Code Channels.

One or more of the 16 Code channels can be used to provide an Orthogonal Channel Noise Source (OCNS) on an otherwise un-used Walsh code.

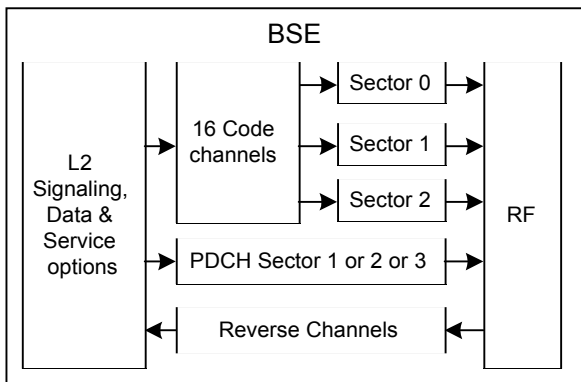

Functional deployment of a BSE

The Code channels can be routed to up to 3 sectors at the same time with the exception of PDCH that can be routed to only one of the three sectors. Each of the sectors can be programmed independently with different power levels and propagation delays.

A BSE allows the reception of a single reverse channel. However it can be configured to acquire/ search multiple channels before decoding the acquired channel. The system supports the following reverse channels.

- Access and Enhanced Access Channels
- Fundamental Channel
- Supplemental and Supplemental Code Channels
- Dedicated and Common Control Channels
- Acknowledgment and Channel Quality Indicator channels

DV FEATURES

The 6402 AIME system supports the following key features.

- Support for all 127 configurations - number of slots, encoder packet sizes and number of Walsh codes
- Ability to change between configurations every subpacket
- Emulation of base station scheduling of subpackets to multiple mobiles
- Controllable assignment of Ec/Ior values on a subpacket basis
- Transmit valid data on both PDCCH0 and PDCCH1
- Transmit valid data on PDCH0 or PDCH1
- Controllable selection of valid PDCCH / PDCH on a subpacket basis
- Support for 1, 2, 3 or 4 ARQ channels
- Support for ACK delay of 1 and 2
- Controlled retransmission (with ACK / NAK) - open and closed loop
- Retransmission of sub-packets after a specified minimum delay
- Control of Walsh mask transmission
- Simultaneous transmission of Walsh Mask on PDCCH0 and valid subpacket on PDCCH1 / PDCH1
- Cell switching based on REV_CQI_COVER or a specified CQI cover
- Early Termination including controllable number of Extended Messages
- Enable / Disable / Time Reversed system time scrambling on PDCCH
- Enable/Disable scrambling on PDCH

POWER CONTROL TESTING

Normally the system uses the automatic Closed Loop Power Control of the mobile station to hold its power at an optimum level. However, the user has full control of this process using scripts if required.

Each sector can be configured with its own Forward Traffic channels and there is independent power control of the corresponding power control sub-channel. These can be different for each sector, thereby enabling the user to test the behavior of the mobile station under soft handoff situations.

The 6402 AIME system can be programmed to respond to Fast

Forward Power Control requests from the cell phone to the base station to alter the power it transmits to the cell phone. The power level increments are defined by the user. This is particularly useful for testing the performance of the mobile under fading channel conditions. The 6402 AIME system responds to requests from the mobile whilst retaining (where possible) the total power transmitted by the base station.

HANDOFF / CELL SWITCHING CAPABILITY

A single BSE can support 3-way soft and softer handoff as well as hard handoff to the same frequency. A system configured with two BSEs can support hard handoff to a different frequency. It can also support six-way soft handoff.

PILOT POLLUTION TESTING

The fine control of the 6402 enables the System to be used for simulating pilot pollution scenarios for R&D testing of Mobile Stations. The output power of the Forward Channels in each code channel can then be varied. This allows the user to vary the relative pilot levels in a completely controlled and repeatable manner.

PROTOCOL TESTING

The user is able to emulate Layer 3 protocols via the Application Program Interface (API). Scripts can be generated and modified using the script editor. In addition to this, example scripts are provided and can be modified by the user and built up into a library for continued use.

Aspects of Layer 2 behavior can be modified under script control to enable the user to investigate and test these aspects of the performance of the mobile station under test.

Logging with full message decoding is a key feature of the debug capability. All Forward and Reverse link Layer 2 and 3 messages are logged and time-stamped on the PC for subsequent review.

SERVICE OPTION SUPPORT

The majority of non-proprietary Service Options are supported. Where data service options utilize application layers above Air Interface Layer 3, standard commercial off-the-shelf (COTS) software may be used where applicable. For further details contact your local representative.

Summary of Service Options supported:

Service Option Number	Designated/Type of Service
1	Basic Variable Rate Voice Service (8 kbps)
2	Mobile Station Loop-back (8 kbps)
3	Enhanced Variable Rate Voice Service (8 kbps)
4	Asynchronous Data Service (9.6 kbps)
5	Group 3 Facsimile (9.6 kbps)
6	Short Message Services (Rate Set 1)
7	Packet Data Service: Internet Protocol Stack only (Rate Set 1)
9	Mobile Station Loop-back (13 kbps)
12	Asynchronous Data Service (14.4 or 9.6 kbps)
13	Group 3 Facsimile (14.4 or 9.6 kbps)
14	Short Message Services (Rate Set 2)
15	Packet Data Service: Internet of ISO Protocol Stack (14.4 kbps)
18	Over-the-air Parameter Administration

	(Rate set 1)
19	Over-the-air Parameter Administration (Rate set 2)
22	Medium Speed Packet Data Service: Internet Protocol only (RS1 forward, RS1 reverse)
25	Medium Speed Packet Data Service: Internet Protocol only (RS2 forward, RS2 reverse)
32	TDSO Test Data (RS1, RS2)
33	Packet Data
35	Position Location (RS1)
36	Position Location (RS2)
54	IS-2000 Markov (RS1, RS2)
55	IS-2000 Loopback (RS1, RS2)
4100	Service Option 4, revision 1
4101	Service Option 5, revision 1
4103	Service Option 7, revision 1
32,768	High Rate Voice Service (13kbps)
32,798	Rate Set 1 Markov (8k)
32,799	Rate Set 2 Markov (13k)

Other options may be supplied if required.

SYSTEM CONTROL

The 6402 AIME System uses a COM compatible software interface, therefore the user can use the script interpreter built into the User Interface.

SCRIPT LANGUAGE

The 6402 AIME uses an ActiveX scripting engine that allows SAX BASIC (Visual Basic) script to be used to control the system.

PROCEDURES AND TEST CASES SUPPLIED

The 6402 AIME system is supplied with a number of example-scripted procedures. These can be used directly or the user can incorporate them into other scripts. They can be freely copied and modified subject to the license conditions. These procedures include testing aspects of handoff, SMS, pilot pollution, power control, propagation delay, call set-up, etc.

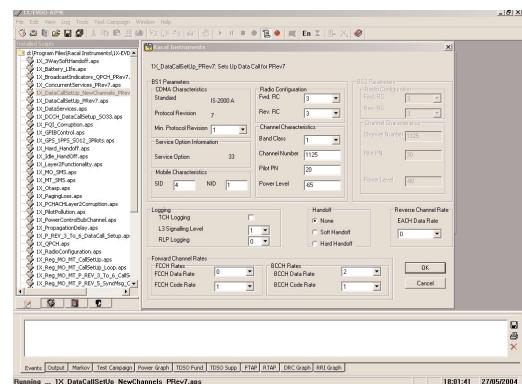

Initial script parameters can be set very easily

CAMPAIGN MANAGER

A campaign manager is included within the system to provide the automation of tests. This enables a series of tests to be assembled so that they can be run without operator intervention. This is particularly useful for applications including regression testing. By using this facility considerable time savings are possible.

SPECIFICATION

RF GENERATOR

FREQUENCY

Range

869 to 894 MHz
1840 to 1870 MHz
1930 to 1990 MHz
2110 to 2170 MHz

Raster

5 kHz

Resolution

< 1 MHz

Accuracy A

s frequency standard

OUTPUT LEVEL

Range (RF Duplex Port):

-30 to -110 dBm

Resolution

0.25 dB

ACCURACY

Relative

+0.5 dB/1 dB step

Absolute

+5 dB

SIGNAL QUALITY ρ

> 0.98

CODE CHANNEL POWER ACCURACY

+ 0.1 dB over 20 dB range

PORTS

RF Duplex Port Connector

N type Female

Impedance / Coupling

50 Ω nom / DC

VSWR

< 1.8:1

Max Reverse power

36 dBm

RF RECEIVER

FREQUENCY

Range

824 to 849 MHz
1750 to 1780 MHz
1850 to 1910 MHz
1920 to 1980 MHz

Raster

5 kHz

Resolution

Can be tuned to any receive channel

Tolerated frequency error

± 300 Hz

INPUT LEVEL

Range (RF Duplex Port):

+36 to -60 dBm

MEASUREMENT ACCURACY (> 45 dBm)

Resolution 0.1 dB

Relative < ± 1 dB/20 dB

Absolute < ± 2 dB

FREQUENCY STANDARDS

EXTERNAL REFERENCE INPUT

Connector

SMA female

Frequency

N x 1, N = 1,2,5,10,12,13 or 15

N x 1.2288, N = 1,2,3,4,6,8,9, 12 or 16

Level

-2 to +19 dBm

Impedance / Coupling

50 Ω nom / AC

REFERENCE OUTPUT

10 MHz (internal standard) or the external reference input frequency

Level

+9 dBm ± 2 dB

Impedance/ Coupling

50 Ω nom / AC

Connector

SMA female

Internal overall stability

For one year ± 0.05 ppm

TIMING MARKERS

Timing signals provided

1.25, 2.5, 5, 20, 26.66 ms, 2 sec and a programmable marker

Accuracy

60 ns

GENERAL

POWER REQUIREMENTS

Voltage range

85-130 V and 180-264 V

Frequency range

47 to 66 Hz

Power consumption

1000 Watts max (excluding PC)

DIMENSIONS AND WEIGHT**Dimensions**

(WHD)

562 mm x 526 mm x 420 mm

Weight

60 kg max

OPERATING TEMPERATURE

10°C to 35°C

Humidity

5% to 85% RH (non-condensing)

EMC

Complies with EN61326-1 :1997+A1 : 1998 , Class A (emissions) ,
EN61326-1 :1997+A1 : 1998 Table 1 (immunity)

Safety

Complies with EN61010-1: 2001

For the very latest specifications visit www.aeroflex.com

CHINA Beijing

Tel: [+86] (10) 6467 2716
Fax: [+86] (10) 6467 2821

CHINA Shanghai

Tel: [+86] (21) 6282 8001
Fax: [+86] (21) 62828 8002

FINLAND

Tel: [+358] (9) 2709 5541
Fax: [+358] (9) 804 2441

FRANCE

Tel: [+33] 1 60 79 96 00
Fax: [+33] 1 60 77 69 22

GERMANY

Tel: [+49] 8131 2926-0
Fax: [+49] 8131 2926-130

HONG KONG

Tel: [+852] 2832 7988
Fax: [+852] 2834 5364

INDIA

Tel: [+91] 80 5115 4501
Fax: [+91] 80 5115 4502

KOREA

Tel: [+82] (2) 3424 2719
Fax: [+82] (2) 3424 8620

SCANDINAVIA

Tel: [+45] 9614 0045
Fax: [+45] 9614 0047

SPAIN

Tel: [+34] (91) 640 11 34
Fax: [+34] (91) 640 06 40

UK Burnham

Tel: [+44] (0) 1628 604455
Fax: [+44] (0) 1628 662017

UK Stevenage

Tel: [+44] (0) 1438 742200
Fax: [+44] (0) 1438 727601
Freephone: 0800 282388

USA

Tel: [+1] (316) 522 4981
Fax: [+1] (316) 522 1360
Toll Free: 800 835 2352

As we are always seeking to improve our products, the information in this document gives only a general indication of the product capacity, performance and suitability, none of which shall form part of any contract. We reserve the right to make design changes without notice. All trademarks are acknowledged. Parent company Aeroflex, Inc. ©Aeroflex 2005.

www.aeroflex.com
info-test@aeroflex.com



Our passion for performance is defined by three attributes represented by these three icons: solution-minded, performance-driven and customer-focused.